

## PRIORITY MODEL OF TOURISM DEVELOPMENT IN PARIAMAN CITY

ERI BARLIAN<sup>1\*</sup>, ISWANDI UMAR<sup>2</sup> AND INDANG DEWATA<sup>3</sup>

<sup>1</sup>Faculty of Sports Science, Universitas Negeri Padang, 25171 Padang, West Sumatra, Indonesia. <sup>2</sup>Geography Department, Faculty of Social Science, Universitas Negeri Padang, 25171 Padang, West Sumatra, Indonesia. <sup>3</sup>Faculty of Mathematics and Natural Sciences, Universitas Negeri Padang, 25171 Padang, West Sumatra, Indonesia..

\*Corresponding author: [e.barlian@fik.unp.ac.id](mailto:e.barlian@fik.unp.ac.id)  
Submitted final draft: 25 October 2023

<http://doi.org/10.46754/jssm.2024.03.008>  
Accepted: 17 November 2023

Published: 15 March 2024

**Abstract:** This study aims to develop tourism development priorities and marine tourism policy directions in Pariaman City. To assess the suitability of marine tourism land, 10 indicators are used, namely water brightness, beach type, beach depth, substrate, current speed, live coral cover, disaster proneness, and accessibility. The analytic hierarchy process approach, considering four criteria—government support, tourism industry, community support, and land availability—is used to determine the tourism potential index. Findings from 10 observation points reveal that two observation locations were very suitable (S1) for marine tourism, four fall into the appropriate category (S2), and the remaining 4 are marginally suitable (S3). Based on the tourism development potential index, the top three priority observation points are P5, P6, and P7. The results indicate that observation point P6 has the highest value, while observation point P2 has the lowest. The prioritised policy direction strategy for developing marine tourism in Pariaman City includes three sub-elements: A6 (attracting investors for marine tourism development), A5 (increasing the frequency of tourist attractions), and A1 (improving beach cleanliness).

Keywords: Maritime, tourism, land suitability, tourism potential.

### Introduction

Tourism can be defined as a series of activities for recreational, business, religious, and health purposes within a limited timeframe in a certain area (Masron *et al.*, 2015). Tourism development is an important strategy in bolstering regional economic growth. The development of tourism has an impact on the development of the tourism industry and employment opportunities (Zhang, 2013). Masron *et al.* (2015) assert that the development of tourism has the potential to draw in three to five percent of a state's workforce.

Marine tourism significantly contributes to the national economy by generating employment opportunities and other economic activities (multiplier effect), as well as foreign exchange income for the state (Dahuri, 2001). It can be seen as a driver of the national economy, as it involves the vast sea and islands located in strategic positions between two continents and oceans (Riski *et al.*, 2016; Remunusa, 2016). Marine tourism is a form of tourism that prioritises the beauty of the natural coast and marine environments (Yani, 2018; Putra *et al.*, 2023a, 2023b).

The prospects for the tourism industry in Indonesia are very promising considering the country's abundant natural wealth (Sukadijo, 2001). The tourism sector makes a substantial contribution to the national gross domestic product (GDP), directly accounting for around 4.1%, and 9% indirectly. The sector has also proven resilient amidst global crises. The Visit Indonesia Year 2019 initiative, for instance, drew 6.5 million foreign tourists, generating approximately US\$7.5 million in foreign exchange (Palupi *et al.*, 2019).

Hawkes *et al.* (1998) highlighted that natural beauty and diversity significantly attract tourists to an area. Salehudin *et al.* (2013) and Masron *et al.* (2015), meanwhile, stated that most tourists are more interested in marine tourism objects. Indonesia, boasting two-thirds of its territory as sea area and a coastline stretching 99,093 km, holds immense potential for tourism development. Statistical data from 2010 to 2022 indicate an average annual increase of approximately 7% in tourist visits

to Indonesia. In 2010, the country welcomed 493,799 visitors, a figure that surged to 740,450 by 2022. The rise in foreign tourist arrivals contributed significantly to the state’s income, reaching US\$3.563 billion(BPS, 2016).

Pariaman City is known for its annual Tabuik cultural festival, celebrated from the 1st to the 10th of Muharram every Islamic calendar year. However, over the past three years, both domestic and international tourist visits to Pariaman City have declined by 35%. Consequently, this research is necessary for determining the direction of tourism development policy in Pariaman City, West Sumatra Province, Indonesia. What sets this research apart is the absence of a policy framework for developing coastal areas. It is hoped that the findings of this research will serve as a reference for the Pariaman City government in boosting local income, particularly for the community.

**Methods**

**Research Location and Time**

This research was conducted in Pariaman City, situated between 00° 33’ 00’’ – 00° 40’ 43’’ South Latitude and 100° 04’ 46’’ – 100° 10’ 55’’ East Longitude. Geographically, Pariaman City is located on the West Coast of Sumatra Island, facing the Indian Ocean. It borders Padang Pariaman Regency to the north, south, and east (Fig 1). This study spanned six months, from May 2023 to October 2023.

Pariaman City, located in West Sumatra province, had a population of 95,519 people in 2021. of the city econmpasses sloping lowlands along the west coast of Sumatra, ranging from two to 35 metres above sea level, It boasts a coastline stretching 12.7 km and is home to six small islands: Bando Island, Gosong Island, Ujung Island, Tangah Island, Angso Island, and Kasiak Island.

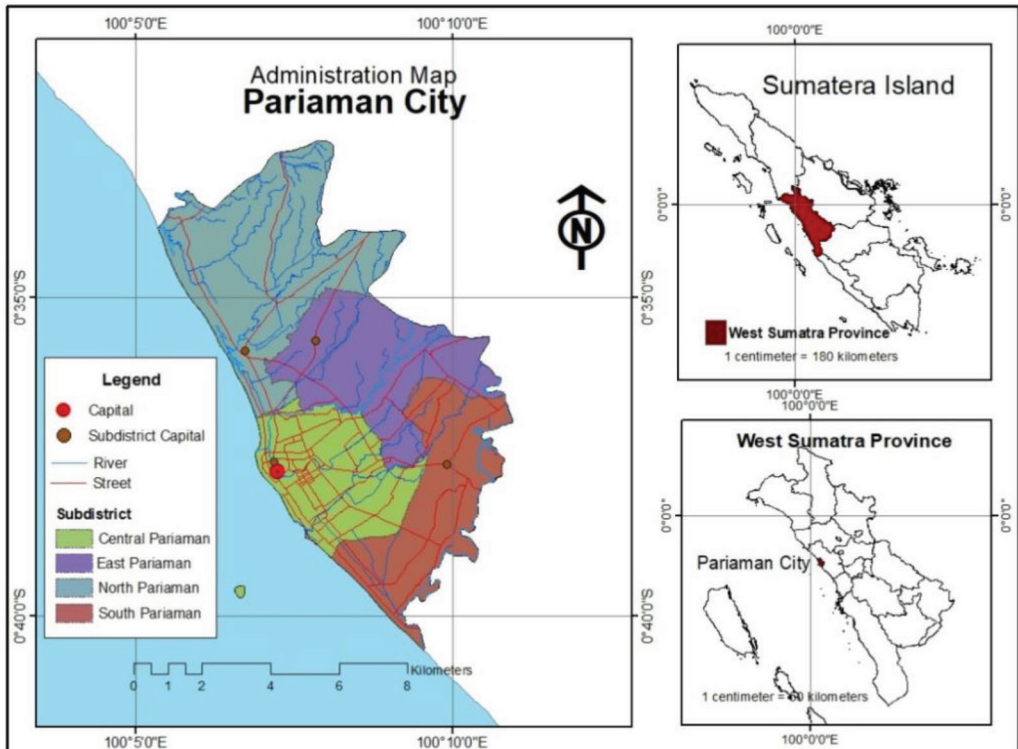

Figure 1: A map of the research location of Pariaman City

**Data Analysis Technique**

The suitability of land for tourism areas was assessed using criteria established by the United States Department of Agriculture (USDA) (1971), Hardjowigeno and Widiatmaka (2007), Aklibasinda and Bulut (2014), and Putra *et al* (2023c). The criteria are water brightness,

beach type, beach depth, substrate, current speed, live coral cover, disaster proneness, and accessibility. Each criterion is further divided into sub-criteria. The score is determined by multiplying the weight of each criteria with the value of the sub-criteria. Table 1 outlines the criteria used to determine the suitability of land for tourism areas.

Table 1: Land suitability criteria for coastal tourism areas

Criteria/Weight	Sub Criteria	Weight	Score
Brightness of waters (15)	15-20	4	60
	10-15	3	45
	5-10	2	30
	<5	1	15
Beach type (15)	Sloping sand	4	60
	The sand is rocky and muddy	3	45
	Sand, rocky and a bit steep	2	30
	Steep coral beach	1	15
Beach depth (15)	0-3 metre	4	60
	3-5 metre	3	45
	5-10 metre	2	30
	>10 metre	1	15
Substrate (10)	Sand	4	40
	Sandy coral	3	30
	Muddy sand	2	20
	Mud	1	10
Current speed (10)	0-0.17 metre/second	4	40
	0.17-0.34 metre/second	3	30
	0.34-0.51 metre/second	2	20
	>0.51 metre/second	1	10
Live coral cover (5)	>70%	4	20
	50-70%	3	15
	20-50%	2	10
	< 20%	1	5
Disaster prone (15)	Very low	5	75
	Low	4	60
	Moderate	3	45
	High	2	30
	Very high	1	15
Accessibility (10)	Very easy	5	50
	Easy	4	40
	Quite easy	3	30
	Difficult	2	20
	Very difficult	1	10

To determine the land suitability zoning interval class for coastal tourism areas, Equation 1 is used:

$$I = \frac{c - b}{k}$$

Where,

I = large class interval distance

c = number of highest scores

b = number of lowest scores

k = number of desired classes

Based on Table 1, the highest total score is 405, while the lowest total score is 95. Four categories of class groups will be determined: very suitable (S1), suitable (S2), marginally suitable (S3), and not suitable (N). So, the class interval obtained is 78. Table 2 shows the land suitability classes for coastal tourism areas.

To determine the development potential assessment index, expert opinions are solicited

using the analytic hierarchy process (AHP) method. Experts assign ratings based on a pairwise comparison using a scale ranging from 1 to 9. The scale, as defined by Saaty (1983) and Marimin and Maghfiroh (2010), for expert opinion on a comparative scale is presented in Table 3.

To analyse the data, the Expert Choice 2011 software was used. According to Marimin and Maghfiroh (2010) and Umar (2016), an acceptable consistency ratio (CR) value is less than 0.1. Figure 2 illustrates the hierarchical structure of potential beach tourism development in Pariaman City. The results of the expert assessment regarding the priority index for developing coastal tourist attractions are presented in Table 4.

Determining priority zones for the development of coastal tourist attractions in

Table 2: Suitability class for coastal tourism areas

Conformity Class	Interval Class	Suitability Index for Coastal Tourism Areas
Very suitable (S1)	330-405	The beach tourist zone is very suitable
Sesuai (S2)	252-329	Beach tourism zone is appropriate
Sesuai marginal (S3)	173-251	The coastal tourist zone is marginal
Not suitable (N)	95-172	The beach tourist zone is not suitable

Source: USDA (1971), Hardjowigeno and Widiatmaka (2007), Aklibasinda and Bulut (2014), Umar (2018)

Table 3: Assessment criteria in AHP

Mark	Information
1	A is as important as B
3	A is slightly more important than B
5	A is clearly more important than B
7	A is clearly more important than B
9	A is absolutely more important than B
2, 4, 6, 8	When in doubt between two adjacent values

Source: Saaty (1983), Marimin and Maghfiroh (2010)

Table 4: Expert assessment index

Index Class	Interval	Information
High	> 0.25	Very well developed
Moderate	0.15-0.25	Good enough to be developed
Low	< 0.15	Not good for development

Source: Umar (2017)

Pariaman City is guided by the model developed by Umar (2017). Prioritising the development of tourist attractions involves evaluating the suitability of land and the potential index for tourist attraction development. The priority zone for tourist attraction development is the very suitable zone (S1) with a high index class determined through expert assessment. Therefore, to determine regional development priorities, Equation 2 is used:

$$Pr = Kow \times Ppw$$

Where,

Pr = priority for developing tourist attractions

Kow = land suitability score for tourist attractions

Ppw = tourist attraction development potential index score

To determine policy direction in developing marine tourism objects, the Interpretative Structural Modelling (ISM) method is employed. First introduced by Warfield (1974) and further developed by Saxena *et al.* (1992), ISM proves highly effective in addressing highly complex problems. In this research, obstacles to marine tourism development are identified based on expert opinions obtained through purposive sampling. The experts engaged encompass tourism specialists, community leaders, representatives from tourism businesses, and local governments officials. The stages of the ISM method, as described by Marimin (2005), Eriyatno dan Larasati (2013), and Umar and Dewata (2017) involve (1) decomposing elements into several sub-elements; (2) establishing contextual relationships between sub-elements; (3) determining the structural self-interaction matrix (SSIM); (4) formulating the reachability matrix; (5) ensuring transitivity; (6) establishing the vertical hierarchical structure; and, (7) determining the driver power (DP) and dependence (D) relationship matrix. The SSIM is created through pairwise comparison with the symbol VAXO, where

V if  $E_{ij} = 1$  and  $E_{ji} = 0$ ; V = the *i*th sub-element plays a greater role than the *j*th sub-element and not vice versa.

A if  $E_{ij} = 0$  and  $E_{ji} = 1$ ; A = the *j*th sub-element plays a more important role than the *i*-th sub-element and not vice versa.

X if  $E_{ij} = 1$  and  $E_{ji} = 1$ ; X = both sub-elements have the same role level value and are interrelated, and.

O if  $E_{ij} = 0$  and  $E_{ji} = 0$ ; O = the two sub elements are not related to each other

Furthermore, contextual relationships between elements can be divided into four categories, namely Autonomous (first quadrant), Dependence (second quadrant), Linkage (third quadrant), and Independent (fourth quadrant). Marimin (2005) delineates the four quadrants as follows: elements situated in the Autonomous quadrant exhibit minimal or no relationship with the system; those in the Dependence quadrant exert weak influence but maintain high relationships with other variables; the Linkage quadrant encompasses elements with high influence and strong relationships with other variables; and, finally, the Independent quadrant accommodates elements with substantial influence but minimal relationships with other variables.

## Results

Tourism has long been recognised as a powerful and influential economic sector within a country. With the number of international tourists continuing to increase from year to year, it is important to understand the positive, negative, and solutions to the negative impacts that the industry has on economic growth and development. Indonesia's maritime wealth contributes to its extensive maritime tourism potential, each region boasting its own distinct beauty and uniqueness. From Sabang to Merauke, Indonesia's marine tourism potential stretches far, offering avenues for exploration and discovery.

The tourism sector is a business that involves the provision of services and goods to tourists and encompasses every expenditure made by tourist visitors. In the contemporary era, tourism development constitutes a key component of

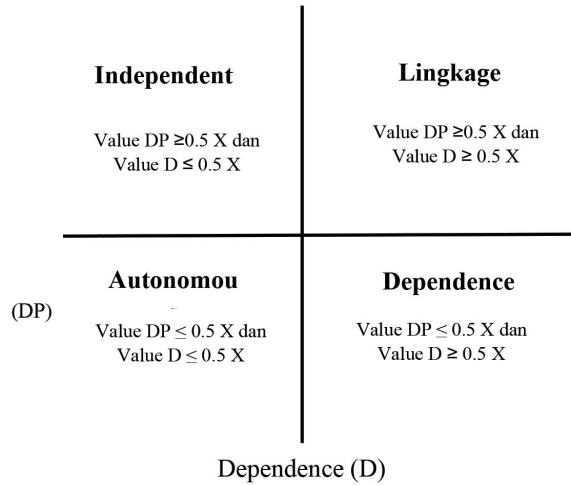

Figure 2: The driver power and dependence relationship matrix in ISM

economic growth strategies within a country. The development of tourism in an area yields positive economic impacts and serves as a source of regional income. Additionally, the tourism industry has exhibited rapid growth compared with other economic sectors and has emerged as a solution in bolstering the Indonesian

economy, as it can contribute to foreign exchange generation and is expected to expand employment opportunities, foster job creation and stimulate local businesses (Kurniawan, 2015). The current status of the coastal areas in Pariaman City, which is now mostly developed as tourist destinations, is detailed in Table 5.

Table 5: Overview of beach tourism locations in Pariaman City

Beach	Characteristics
Teluk Belibis	Sloping with a gradient of 0-2%, bordered by trees, and the beach is surrounded by residential land. The sand is ivory yellow and without mud, but with murky seawater, particularly in rainy weather. The maximum wave height is 1.2 m, and the maximum beach width is 25 m.
Pasir Putih	Relatively gentle slope of 0-2%, with some rocky areas at the periphery, amidst residential surroundings. The sand is ivory yellow and without mud, but the seawater is murky, especially when it rains. The maximum wave height is 1.2 m, and the maximum beach width is 25 m.
Ampalu	Relatively gentle slope (0-2%) with rocky patches on the outskirts, amidst residential areas. The sand is ivory yellow without mud, and the seawater tends to be murky, especially during rainfall. The maximum wave height is 1.2 m, and the maximum beach width is 20 m.
Pauh	Relatively gentle slope (0-2%) with rocky sections at the edges, surrounded by residential land. The sand is ivory yellow and without mud, and seawater clarity decreases during rainy periods. The maximum wave height is 1.2 m, and the maximum beach width is 20 m.
Gandoriah	Relatively gentle slope (0-2%) with rocky patches along the periphery, amidst residential zones. The sand is ivory yellow and without mud, and seawater clarity diminishes in rainy conditions. The maximum wave height is 1.2 m, and the maximum beach width is 15 m.



Beach	Characteristics
Cermin	Relatively gentle slope (0-2%) with rocky portions nearby, amidst residential settings. The sand is ivory yellow and without mud, and seawater clarity decreases during rainy periods. The maximum wave height is 1.2 m, and the maximum beach width is 15 m.
Kata	Relatively gentle slope (0-2%) with rocky sections on the outskirts, surrounded by residential areas. The sand is ivory yellow and without mud, and seawater clarity decreases during rainfall. The maximum wave height is 1.2 m, and the maximum beach width is 20 m.
Sunur	Gentle slope (0-2%) with rocky areas at the periphery, amidst residential surroundings. The sand is ivory yellow and without mud, and seawater clarity decreases during rainy periods. The maximum wave height is 1.2 m, and the maximum beach width is 22 m.

Source: Field survey, 2022.

The impact of tourism development on socio-economic conditions cannot be avoided. According to Pitana and Gayatri (2005), tourism brings changes to the environment even before the actual activities start. To evaluate the suitability of marine tourism sites in Pariaman City, 10 observation points were identified, which are

illustrated in Figure 3. The analysis, delineated in Table 1, indicates that two observation points are highly suitable (S1) for marine tourism, while four are moderately suitable (S2), and the remaining four are marginally suitable (S3). Further details are presented in Figure 4.

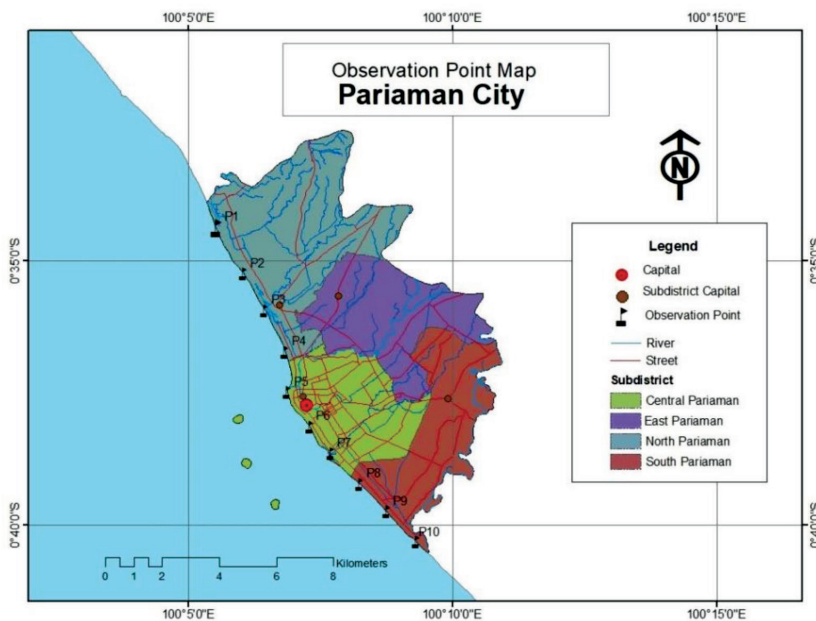

Figure 3: The observation points for marine tourism in Pariaman City

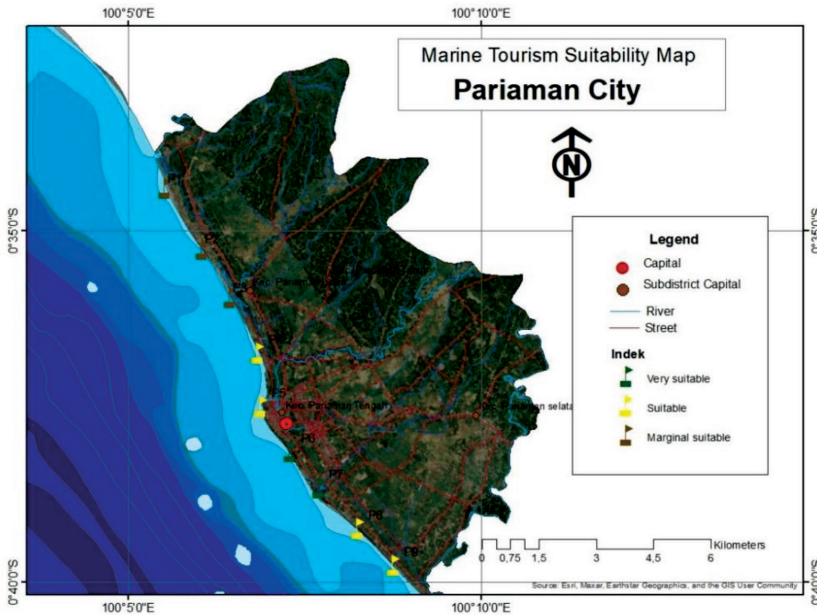

Figure 4: The map showing land suitability for marine tourism in Pariaman City

To assess the potential index for marine tourism development in Pariaman City, the AHP method was employed, involving experts in decision analysis. A total of 20 experts participated in the analysis, representing various stakeholders, namely university experts, non-governmental organisations, the Pariaman City tourism office, traditional leaders, religious leaders, and the tourism industry. The AHP

analysis considers four criteria: government support, tourism industry, community support, and land availability. Among these four criteria, community and government support emerged as the most influential criteria in decision-making. For clarity, Figure 5 illustrates a hierarchy of potential indices for marine tourism development.

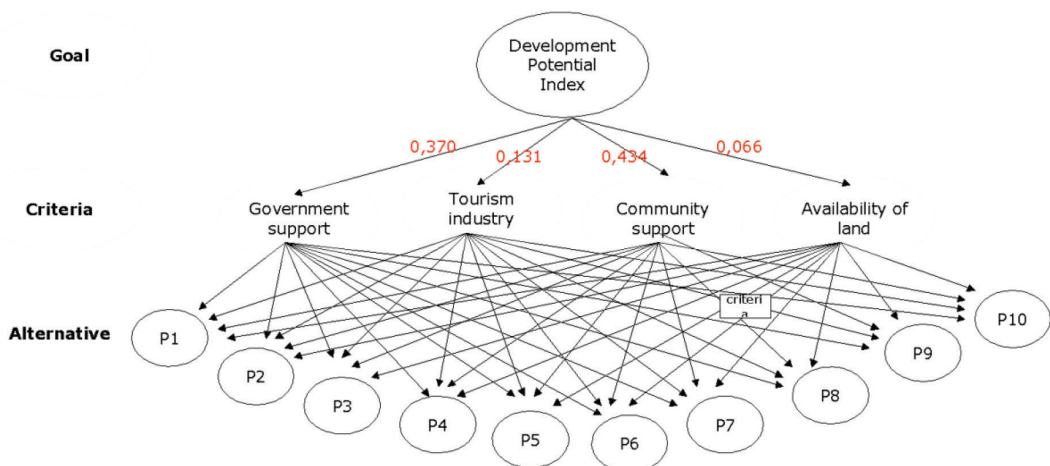

Figure 5: The hierarchy of potential indices for marine tourism development in Pariaman City



**Model Name: Indek potensi pariwisata**

**Synthesis: Summary**

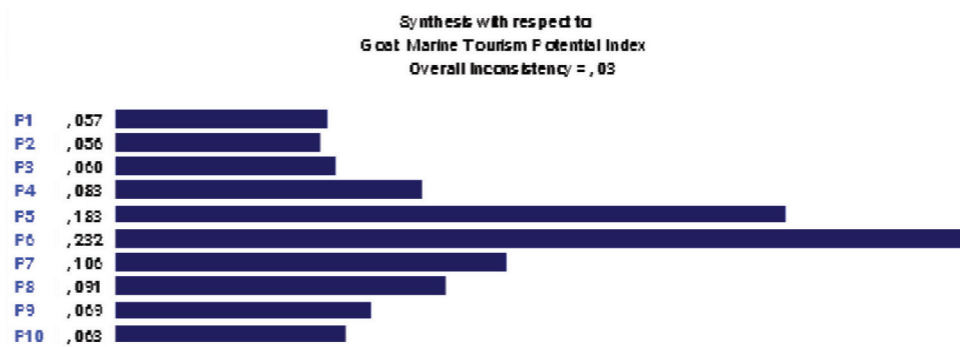

Figure 6: Marine tourism development potential indices for Pariaman City

Figure 6 presents the result of the potential index analysis for marine tourism development in Pariaman City using the AHP method. The analysis indicates three alternative decisions regarding the most important objects for marine tourism development in Pariaman City: observation points P6 (0.232), P5 (0.183), and P7 (0.106). Additionally, to determine the priority for marine tourism development, the evaluation value of the marine tourism land suitability is multiplied by the development potential index. The results show that observation point 6 has the highest value, while observation point P2 has the lowest. The details are presented in Table 6.

In tourism development there are four components that must be fulfilled, namely attractions, accessibilities, amenities, and ancillary services. Attractions encompass features that entice visitors, such as natural beauty, and regional culture. Accessibility refers to the transportation options available to reach and move within the tourism area, such as flights, trains, bus or ship routes and local transportation modes. Amenities, or facilities, comprise accommodations like hotels, homestays, and hostels, along with restaurants, health facilities, souvenir shops, entertainment venues, waste management facilities, and utilities such as

Table 6: The priorities for potential development of marine tourism in Pariaman City

No	Observation Point	Total Shoes	Potential Index	Priority Score	Rank
1.	P1	235	0.057	13.4	9
2.	P2	220	0.056	12.3	10
3.	P3	245	0.060	14.7	8
4.	P4	255	0.083	21.2	5
5.	P5	300	0.183	54.9	2
6.	P6	340	0.232	78.9	1
7.	P7	345	0.106	36.6	3
8.	P8	300	0.091	27.3	4
9.	P9	265	0.069	18.3	6
10.	P10	245	0.063	15.4	7

Source: Analysis results, 2023.

electricity and clean water. Ancillary services are provided by tourism-related organisations that are needed to serve tourists, such as hotel associations, tour guide associations, and travel agency associations.

Indonesia’s tourism development policy develops in line with political developments. Two laws governing tourism, namely Law 9/1990 and Law 10/2009, are products of Indonesia’s tourism development policy under different political conditions. The objective of Indonesia’s tourism development policy is to realise the national goals of the Indonesian nation through tourism development, as articulated in the Preamble to the 1945 Constitution. This article aims to understand the paradigm shift in Indonesia’s tourism development policy by analysing Law 9/1990 and Law 10/2009 in relation to the national aspirations outlined in the Constitution’s preamble. By employing the ISM method through focus group discussions, seven strategies were identified as policy directions for developing marine tourism in Pariaman City. Expert opinions were used to analyze the priority strategy income and key elements:

- A1. Improve beach cleanliness
- A2. Repair and improve tourism supporting infrastructure
- A3. Increase public awareness of the economic impact of tourism
- A4. Evaluate and improve tourism operator services
- A5. Increase the frequency of tourist attractions
- A6. Attract investors for marine tourism development
- A7. Enhance ease of tourist accessibility

Figure 7 depicts the relationship between driving power and dependency in marine tourism development policies in Pariaman City. In this graph, three sub-elements (A6, A5, A1) are situated in the Independent quadrant. Sub-elements located in the independent quadrant signify a substantial driving force with low dependence on other sub-elements. Additionally, Figure 8 illustrates the hierarchical structure of policy directions, where the three sub-elements serve as priority policy directions in developing marine tourism in Pariaman City.

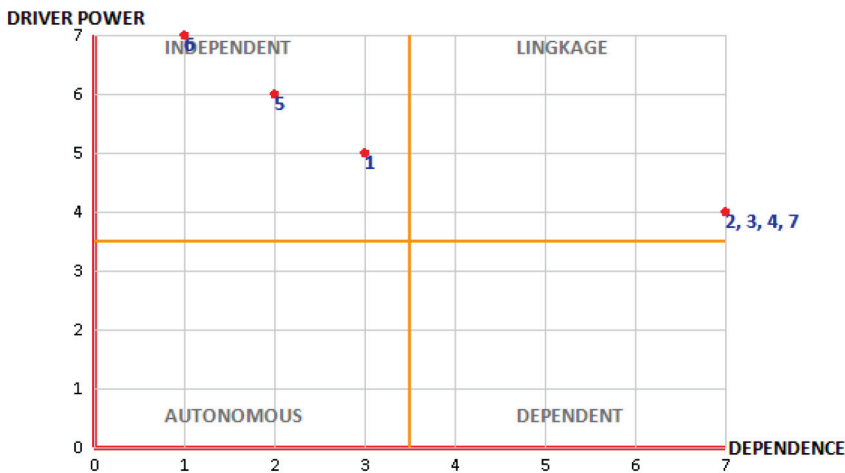

Figure 7: A graph of the relationship between driving power and dependency in marine tourism development policies in Pariaman City

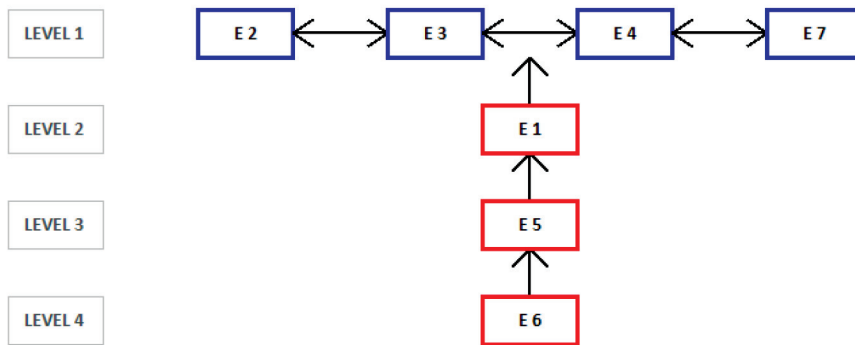

Figure 8: Hierarchical structure outlining marine tourism development policies in Pariaman City

## Conclusions

Pariaman City holds significant potential for marine tourism development. Based on the results of the land suitability evaluation of 10 observation points, two locations are deemed highly suitable (S1) for marine tourism, while four fall into the suitable category (S2), and the remaining four are marginally suitable (S3). The analysis identifies three key locations crucial for marine tourism development in Pariaman City: observation points P6 (0.232), P5 (0.183), and P7 (0.106). Moreover, to prioritise marine tourism development, the evaluation value of land suitability is multiplied by the development potential index. Notably, observation point 6 emerges with the highest value, while observation point P2 records the lowest. The priority policy direction for marine tourism development in Pariaman City includes three sub-elements: A6 (attracting investors for marine tourism development), A5 (increasing the frequency of tourist attractions), and A1 (improving beach cleanliness).

## Acknowledgements

This article was compiled from the results of annual collaborative studies by lecturers at the Universitas Negeri Padang. We would like to extend our gratitude to all individuals who participated in the interviews and literature collection, with special thanks to the Pariaman City regional government.

## Conflict of Interest Statement

The authors declare that they have no conflict of interest.

## Reference

- Aklibasinda, M., & Bulut, Y. (2014). Analysis of terrains suitable for tourism and recreation by using Geographic Information System (GIS). *Environmental Monitoring and Assessment*, 186(9), 5711-5720.
- Aziz, Z., Subardjo, P., & Pratikto, I. (2012). Study of the suitability of Tanjung Setia coastal waters as a marine tourism area in West Lampung Regency, Lampung Province. *Journal of Marine Research*, 1(2), 125-134.
- Baja, S. (2012). *Land use management in regional development*. Yogyakarta: Andi Publisher.
- Central Statistics Agency [BPS]. (2020). *Indonesia in numbers*. Jakarta: Central Bureau of Statistics.
- Central Statistics Agency [BPS]. (2022). *Pariaman City in numbers*. Pariaman: Central Bureau of Statistics.
- Dahuri, R. (2001). *Integrated management of coastal and ocean resources*. Bogor: Pradnya Paramita.
- Eriyatno & Larasati, L. (2013). *Systems science improves management integration and*

- coordination*. Surabaya (ID): Guna Widya Pr.
- Harjowigeno, S. (1988). *Application of land surveys for non-agricultural sectors*. Bogor: Bakosurtanal.
- Hardjowigeno, S., & Widiatmaka. (2007). *Evaluation of land suitability and land use planning*. Yogyakarta: Gadjah Mada University Press.
- Hawkes, S., Williams, P., & Penrose, R. (1998). Tourism industry perspectives on the cariboo-chilcotin CORE process. *Environments*, 25(2), 48-51.
- Law Number 32 of 2009 concerning Environmental Protection and Management. (2009). Indonesia.
- Marimin. (2005). *Techniques and applications of compound criteria decision making*. Bogor: IPB Press.
- Marimin & Maghfiroh, N. (2010). *Application of decision making and supply chain management techniques*. Bogor: IPB Press.
- Masron, T., Mohamed, B., & Marzuki, A. (2015). GIS base tourism decision support system for Langkawi Island, Kedah, Malaysia. *Theoretical and Empirical Researches in Urban Management*, 10(2), 21-35.
- Palupi, R. D., Ira & Risfandi. (2019). Namu Village marine tourism development strategy to support the economy of a tourism-aware community. *SME Management*, 14(1).
- Primadany, S. R., Mardiyono & Riyanto. (2014). Analysis of regional tourism development strategy. *Journal of Public Administration (JAP)*, 1(4), 135-143.
- Putra, A., Dewata, I., Hermon, D., Barlian, E., & Umar, G. (2023). Sustainable development-based coastal management policy development: A literature review. *Journal of Sustainability Science and Management*, 18(1), 238-246.
- Putra, A., Dewata, I., Hermon, D., Barlian, E., Umar, G., Widodo, T., & Damanhuri, H. (2023). Activity recommendations based on an environmental approach in zoning of Marine Protected Areas (MAPS) Pariaman City-Indonesia. *EnvironmentAsia*, 16(3), 57-67.
- Putra, A., Triyatno., Razi, P., Darwis, R., Dewata, I., Mustapha, M. A., Tanto, T. A., & Zainul, R. (2023). Suitability of mangrove ecosystems as a protected zone based on land-use changes. *Physical Oceanography*, 30(5).
- Qomariah. (2009). Community based ecotourism development in Meru Betiri National Park. Bogor.
- Ramenusa. (2016). Marketing Environment Analysis of maritime tourism potential in the Lembah Strait, Bitung City. *Efficiency Scientific Periodical Journal*, 16(3).
- Riski, T. R., Azman, A. H., & Rahmi, F. (2016). Marine tourism development strategy in Padang City, *Journal of Management and Entrepreneurship*, 7(1).
- Saxena, J. P., et.al. (1992). Hierarchy and classification of Program Plan Element Using Interpretative Structural Modelling. *Systems Practice*, 12(6), 651-670.
- Sitorus, S. (1985). *Land resource evaluation*. Bandung: Tarsito.
- So, I. C. (2018). *Potential for development of marine tourism at Pasia Tiku Beach, Agam Regency, West Sumatra Province*. Riau University.
- Soekadijo. (2001). *Tourism management*. Jakarta: PT. Gramedia Library.
- Umar, I. (2016). *Flood disaster mitigation in residential areas in Padang City* (Dissertation). IPB Postgraduate School. Bogor.
- Umar, I., Widiatmaka, Pramudya, B., & Barus, B. (2017). Priorities for residential area development in flood prone areas in Padang City, West Sumatra Province. *Globe Science Magazine*, 19(1), 1-10.

- Unga, K. L., Benyamin, I. M., & Al, R. (2010). Strategy for development of the Banda Island tourism area. *Journal of Public Administration (JAL)*, 1(3), 1-10.
- United States Department of Agriculture [USDA]. (1971). *Guide for interpreting engineering uses of soils*. Washington DC: US. Dept. of Agriculture.
- Warfield, J. N. (1974). *Structuring Complex Systems*. Battelle Monograph No 4. Columbus, Ohio, USA: Battelle Memorial Institute.
- Yulianda, F. (2007). Marine ecotourism as an alternative to conservation-based coastal resource utilization (Presented at the Science Seminar 21 February 2007). Department of Aquatic Resources Management. Bogor Agricultural Institute, Bogor.
- Yulianda, F. (2020). *Aquatic ecotourism is a concept of the suitability and carrying capacity of marine tourism and freshwater tourism*. PT Publisher IPB Press.
- Zhang, J. (2013). The issues facing the sustainable development of rural tourism and the path selection. *Asian Agricultural Research*, 5(9), 5-7.